

GASTRONOMY

A6

GASTRONOMIE A6

The “Gastronomy A6” project in Bolzano’s NOI Techpark offers an exciting gastronomic prospect: a rooftop restaurant in an elaborately renovated Bauhaus building, complete with a terrace offering a fabulous view of the piazza and its iconic water tower. 80 seats inside, 22 outside. A total of 420 m² for a new, contemporary gastronomic concept: a responsible, welcoming and convivial food and drink culture that focuses on quality and puts people first. Do you have a passion for good, honest food and a desire to take gastronomy to the next level? Learn more here:



WHO WE ARE

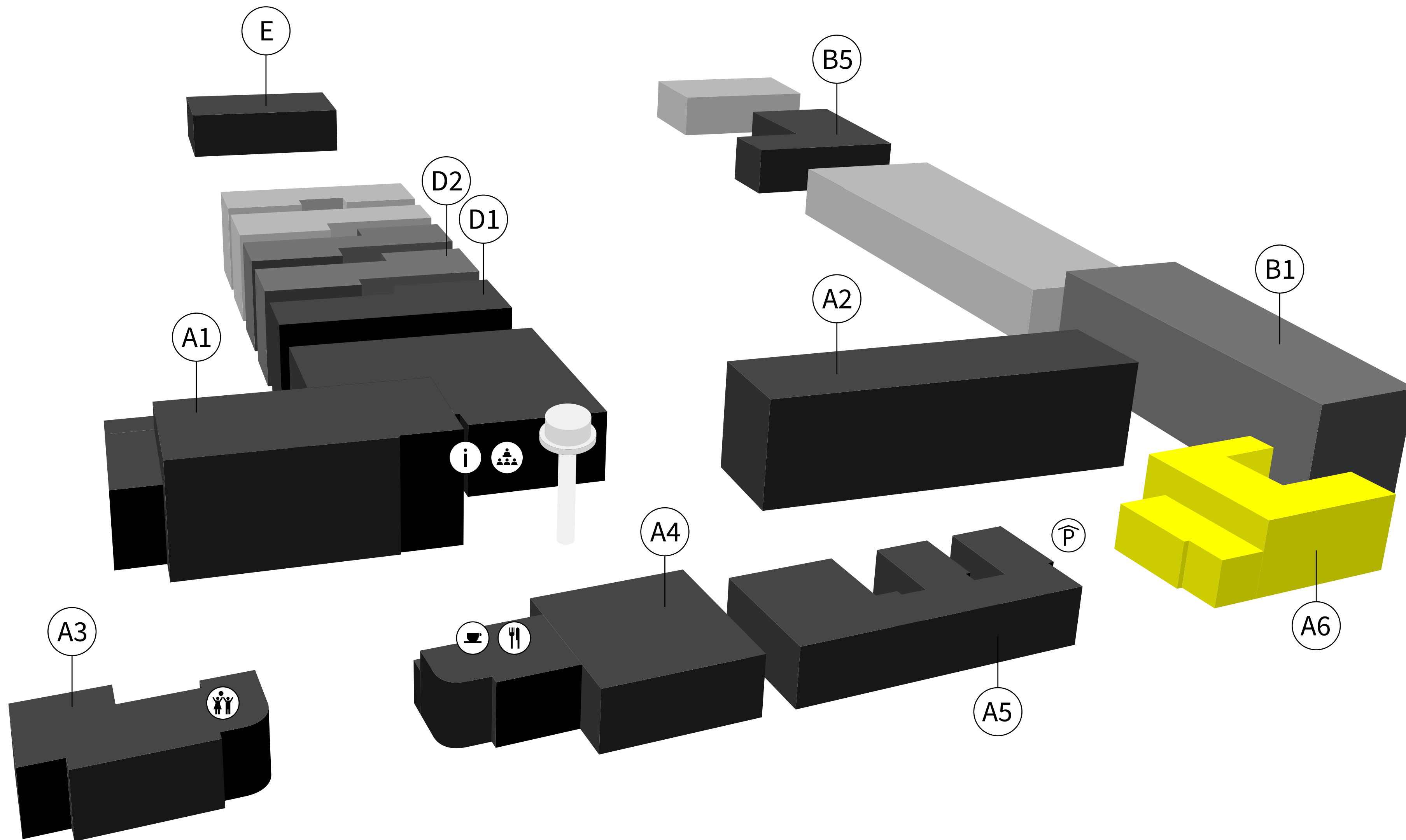

A 12-hectare innovation district in the bustling south of Bolzano. A new urban area and growing campus on the site of a former aluminium plant. An international community inspired by nature and ready to rethink conventional patterns to develop innovative solutions.

Around 120 companies and start-ups, four research institutes, the Free University of Bozen-Bolzano and various institutions and professional associations have come together to work on the future – among other things, in one of our focus areas, the Food & Health technology sector.

GROUND PLANS

Public Transport  →

North/west entrance

Via A. Volta Straße

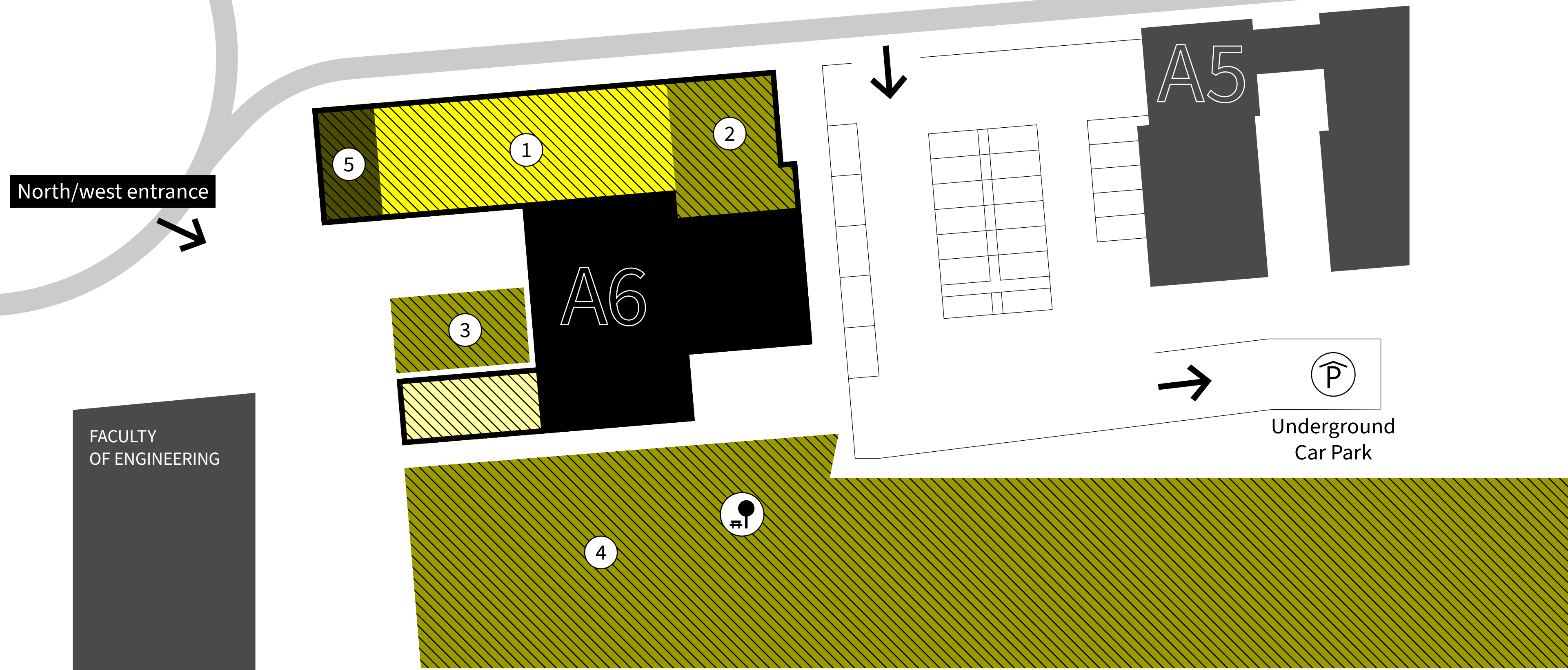

A6

- ① 1st floor restaurant: 80 seats, preparation kitchen, main kitchen
- ② 1st floor rooftop terrace: 22 seats covered
- ③ Patio with terrace: 30 seats
- ④ Public plaza
- ⑤ Staircase

A1

- Kitchen Lab
- Makerspace
- Start-up Incubator
- Institutions (SBB, LVH, HDS, HGV)
- Food start-ups
- Food companies

D2

- Labs: Laimburg Research Centre
- International Center on Food Fermentations
- Food companies

A2

- Micro 4 Food
- Food Technology
- Oenolab
- Laboratory of NMR-Spectroscopy
- Fruit & Vegetable Processing
- Laboratory for Flavours & Metabolites

B1

FACULTY OF ENGINEERING

Public Transport  ↙

WHAT WE OFFER

The unique liveliness and dynamism of an expanding innovation district. A place for culinary delights and food-related events that bring gastronomic innovation to life and appeal to all the senses. A total of around 500 m² of space with state-of-the-art infrastructure.

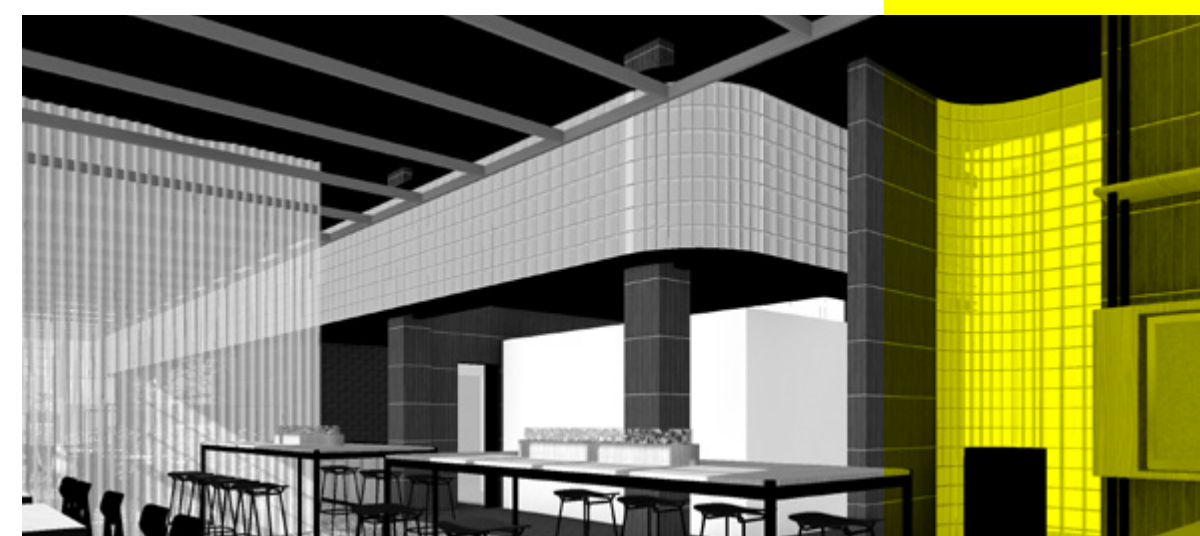
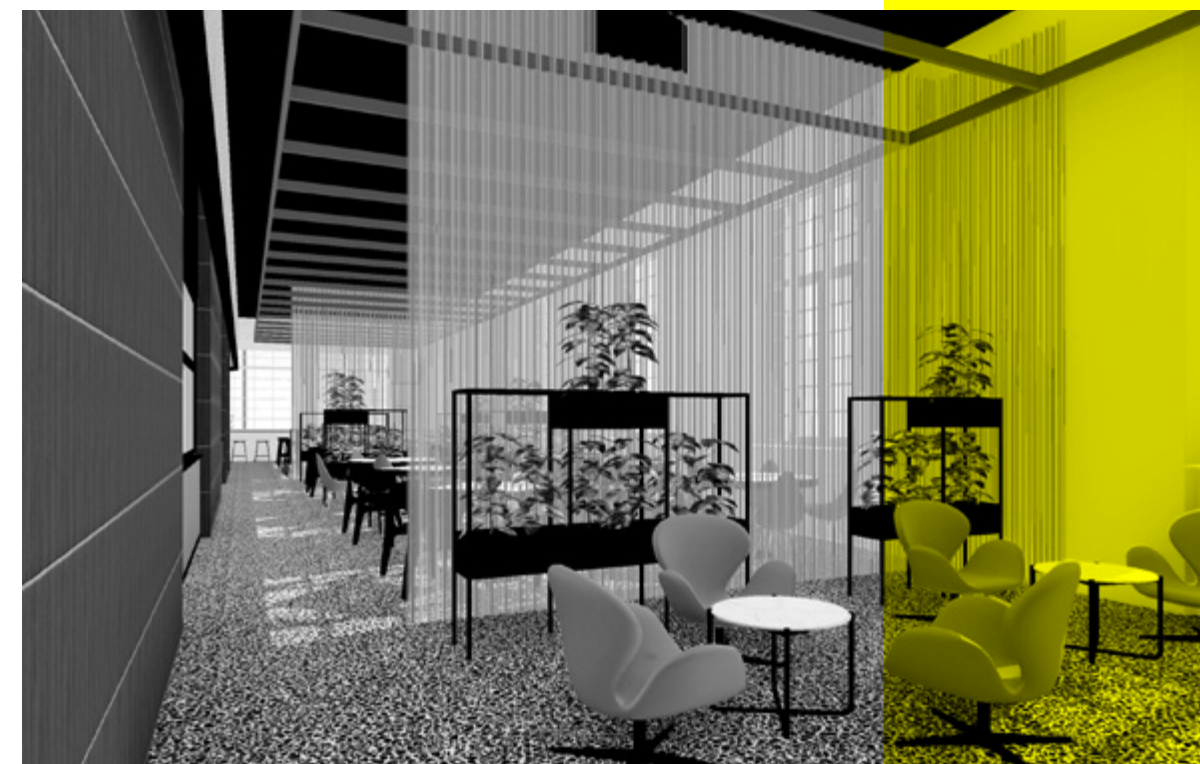

Restaurant

- 80 seats inside (approx. 220 m²)
- 22 seats outside (rooftop terrace, approx. 110 m²)
- Kitchen and bar area (approx. 90 m²):
 - Cold storage room
 - Preparation kitchen
 - Main kitchen
 - Dishwashing area
 - Backstage bar

Basement

- Guest bathrooms
- Storage rooms
- Staff changing rooms, etc.

110mm²

of terrace

WHAT WE OFFER

Plus, extensive expertise in digitalisation, automation and, of course, food science – with an international focus on fermentation.

Key information

- Infrastructure completion planned for spring 2025
- Launch planned for summer 2025
- Distance from the A22 motorway: about 5 minutes by car; distance from the Bolzano Sud railway station on foot: about 15 minutes
- Parking (bike, car) on site
- Potential to expand personal expertise, particularly in the fields of food science, digitalisation and automation
- Opportunities for close dialogue with various technology suppliers near NOI Techpark
- Target group for the restaurant: foodies, architecture and design enthusiasts; people who appreciate high-quality food and are interested in innovation; the NOI community (employees of companies at and near NOI, as well as students; currently approx. 2,400 people)
- Minimum operating hours: Monday–Friday from 11:30 a.m. to 2:30 p.m., excluding public holidays



JOIN US

We are looking for a tenant with an innovative spirit, vision and tenacity. Whether you are an individual, a team or a company – a fresh newcomer, a seasoned pro – a drive to succeed is crucial. We're after someone bold enough to aim high and passionate enough to embark on a forward-looking journey within the inspiring atmosphere of NOI Techpark in Bozen-Bolzano. Are you the ideal fit?

If this sounds like your kind of gastronomic adventure, let's talk!

Ben Schneider

Food Prototyping & Experience
Head of Unit

T +39 0471/066 695
M +39 335/523 73 30
B.SCHNEIDER@NOI.BZ.IT

NOI TECHPARK
SÜDTIROL/ALTO ADIGE

VIA A.-VOLTA-STRASSE 13/A
I-39100 BOZEN/BOLZANO

+39 0471/066 600
INFO@NOI.BZ.IT
WWW.NOI.BZ.IT

FOLLOW US:

